

SILENT KNIGHT
MODEL 5107
FIRE CONTROL/COMMUNICATOR
INSTALLATION MANUAL
REVISED APRIL 1990
PART NUMBER 150455

Table of Contents

1	INTRODUCTION	1
2	TELEPHONE LINES	1
3	FCC REQUIREMENTS	1
4	UL REQUIREMENTS	2
5	FEATURES	2
6	MODEL 5107 CONTROL PANEL DESCRIPTION	2
6.1	PRINTED CIRCUIT BOARD	2
6.2	AC POWER TRANSFORMER	2
6.3	DIALER FAILED LIGHT	2
6.4	BATTERY CABLES	5
6.5	POWER LIGHT	5
6.6	AUDIBLE TROUBLE SIGNAL SILENCED LIGHT	5
6.7	FIRE RESET/AUDIBLE TROUBLE SIGNAL SPEAKER SWITCH	5
6.8	FUSES	5
6.9	EEPROM (Electrically Erasable Programmable Read Only Memory)	5
6.10	DIALER TEST SWITCH	5
6.11	JUMPER WIRE	6
6.12	PLUG-ON CONNECTOR	6
7	DESCRIPTIONS OF FEATURES	6
7.1	CLASS A FIRE LOOP	6
7.2	CLASS B FIRE LOOP	6
7.3	PHONE LINE MONITORS	7
7.4	AUTOMATIC SELF TEST	7
7.5	ADDITIONAL TROUBLE REPORTING	7
7.6	WATCH-DOG CIRCUIT	7
8	MODEL 5107 REPORTING FORMATS	7
8.1	MODEL 9000 RECEIVER DATA USING SK FSK	8
8.2	SILENT KNIGHT FSK FORMAT	9
8.3	RADIONICS HEX FORMAT	10
8.4	SK TO RADIONICS & ADEMCO CONVERSION TABLE	11
9	PROGRAMMING	11
9.1	PROM REMOVAL	12
9.2	PROM INSERTION	12
9.3	PROM PROGRAMMERS	13
9.3.1	MODEL 5506	13
9.3.2	MODEL 5510	14
9.4	PROM CODING FORM FOR THE MODEL 5107 CONTROL/DIALER CHIP	15
9.5	HOW TO SET THE AUTOMATIC SELF TEST TIME	17
10	5107 CONTROL PANEL INSTALLATION	18
10.1	SELECT A LOCATION	18
10.2	MOUNT THE 5107	18
10.3	INSTALL THE 9220 POWER TRANSFORMER	18
10.4	CONNECT ALL INITIATING DEVICES AND ACCESSORIES	19
10.5	CONNECT POWER TO THE 5107	19
11	ZONE WIRING	20

11.1	MODEL 7620 UL LISTED SMOKE DETECTOR	20
11.2	CLASS A ZONES	20
11.3	POWER SUPERVISION UNIT	21
11.4	CLASS B ZONES	21
12	TELEPHONE WIRING	21
12.1	DUAL TELEPHONE LINES	21
13	ACCESSORY WIRING	22
13.1	SUPERVISED ALARM BELL	22
13.2	CONNECTION TO THE MODEL 7171 4-WIRE-LOOP MODULE	23
14	TERMINAL STRIP DESCRIPTION	25
15	TRANSIENT VOLTAGE PROTECTION	26
15.1	EARTH GROUND	26
15.2	5107 EARTH GROUND CONNECTIONS	26
15.3	LIGHTNING PROTECTION	27
15.4	MODEL 5107 UL INSTALLATION REQUIREMENT	27

1 INTRODUCTION

The Silent Knight model 5107 is a combined Control/Communicator. It has been designed for use in a Central Station fire alarm system which needs up to 8 supervised 24 hour fire loops. It includes central station reporting as a built in feature. The reporting can take place over either one or both of two phone lines. Each of these phone lines has its own monitor circuit. Programming information for the telephone lines and on the options is stored in an electrically erasable PROM (EEPROM). The EEPROM does not lose the stored information when electric power is lost. It can be reprogrammed numerous times.

The Silent Knight model 5107 is mounted inside a strong cabinet with a hinged cover. The power is supplied from an UL listed Class II transformer (Model 9220). It is furnished in a package together with one EEPROM, six EOL (End of Line) resistors (Model 7630) and an AC surge suppressor (Model 7890).

2 TELEPHONE LINES

Before this device can be connected to telephone lines, the telephone company must be notified. The following information must be connected to the telephone company

- A. Manufacturer - Silent Knight
- B. Model Number - 5107
- C. FCC registration number - AC 698R-68913-AL-E
- D. Type of jack (to be installed by the telephone company) - RJ31X

NOTE: The telephone company must also be notified if this device is permanently disconnected.

This security system must not be connected to a coin telephone or to party line services.

The telephone company may in some situations be forced to temporarily discontinue service. It may also make modifications in its facilities and in the services which it offers. All this may influence the operation of this device when it is connected to the telephone line. The telephone is required to give sufficient notice in writing of these changes or interruptions in the telephone service.

This device cannot be adjusted or repaired in the field; in case of trouble with the device notify the installing company or return to:

SILENT KNIGHT SECURITY SYSTEMS
1700 Freeway Blvd. N.
Minneapolis, MN. 55430

3 FCC REQUIREMENTS

WARNING: This equipment generates and uses radio frequency energy. If it is not installed and used in compliance with this manual, the equipment may cause harmful interference to radio communications. It has been tested and found to comply with the limits for a class A computing device in accordance with Subpart J of Part 15 of FCC Rules. These FCC rules are designed to provide reasonable protection against such interference when operated in a commercial environment. Operation of this equipment in a residential area may cause interference. If interference should occur, the user may be required to bear the costs of the measures that may be necessary to eliminate the radio frequency interference.

4 UL REQUIREMENTS

The 5107 is UL listed as a Control Unit for use in Central Station Fire-Protective Signaling Systems. Pay special attention to the UL requirements that are listed in this manual. The applicable standard is:

NFPA 71 - Central Station Signaling Systems

5 FEATURES

- * 2 Class A Fire Loops and 6 Class B loops.
- * Detection of ground faults and opens.
- * Dual phone line monitor circuits.
- * Automatic daily test (programmable).
- * Built in automatic battery charger circuit.
- * Built in audible trouble signal speaker
- * Loss of AC and low battery reporting.
- * EEPROM for programming options (non-volatile).
- * 2 built in dual line seizure circuits.
- * Silence audible trouble switch.
- * Rotary or touch tone dialing.
- * 3 reporting formats available.
- * 2 account codes and 2 phone numbers (programmable).
- * Restore reporting.
- * Optional zone annunciator

6 MODEL 5107 CONTROL PANEL DESCRIPTION

6.1 PRINTED CIRCUIT BOARD

Figure 1 depicts the location of many important components on the Model 5107 circuit board. This circuit board contains the microprocessor and other electronic circuits that are required to set up, to monitor, to reset and to test the model 5107 security system. The main components of the system are described in the following sections.

6.2 AC POWER TRANSFORMER

An external transformer (Model 9220) is included with the model 5107 Control/Communicator. This transformer is used to supply 16.5 VAC (45VA) to power the security system. It also supplies charging current to the backup battery. The primary winding of the external transformer is connected to 120 VAC as illustrated in Figure 2. The secondary winding is wired to terminals 1 and 2 of the model 5107.

6.3 DIALER FAILED LIGHT

The red indicator light which is marked Dialer Failed is normally off. It will come on after the control/communicator has been unable to establish contact with the central station receiver after the programmed number of attempts.

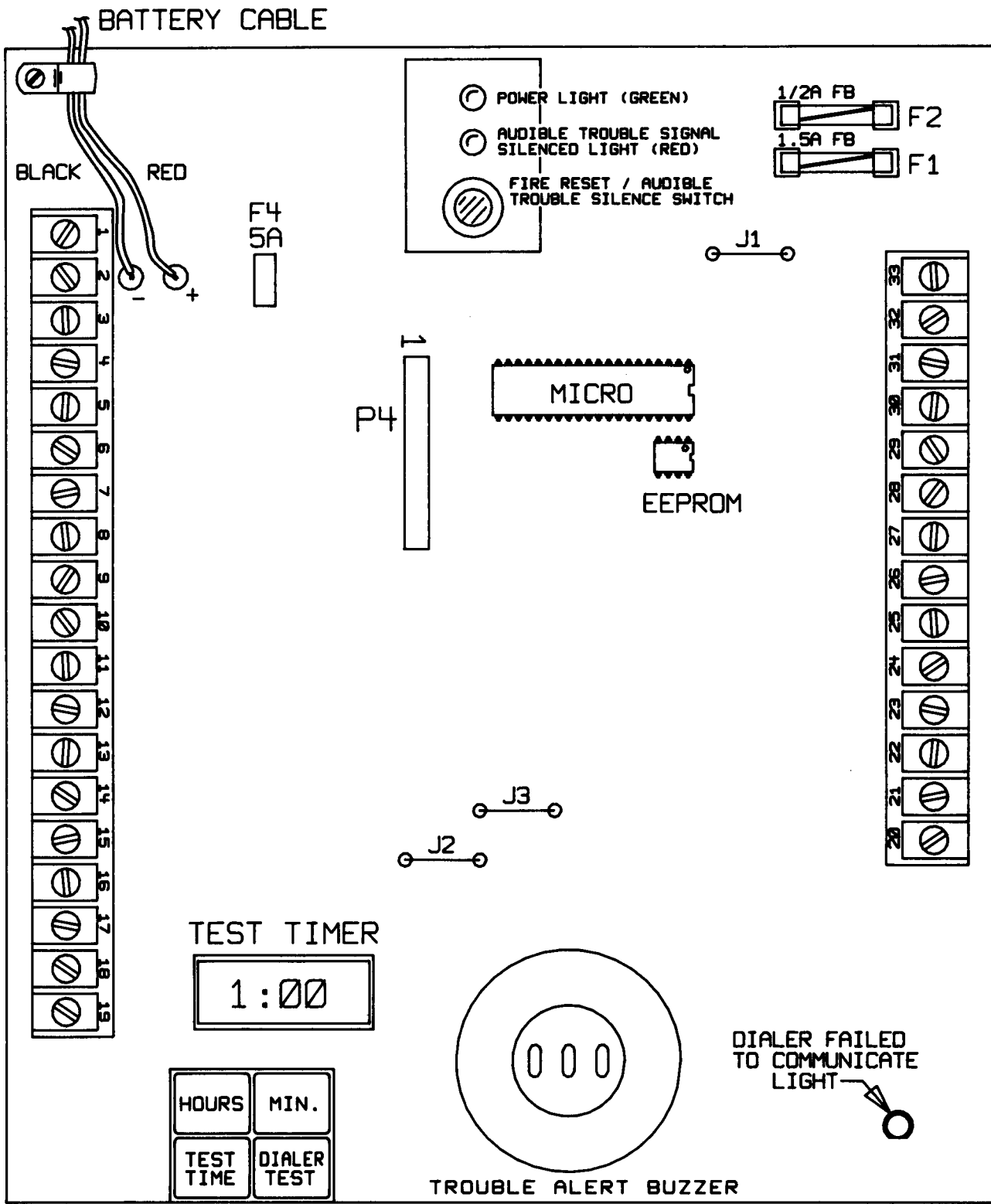

FIGURE 1

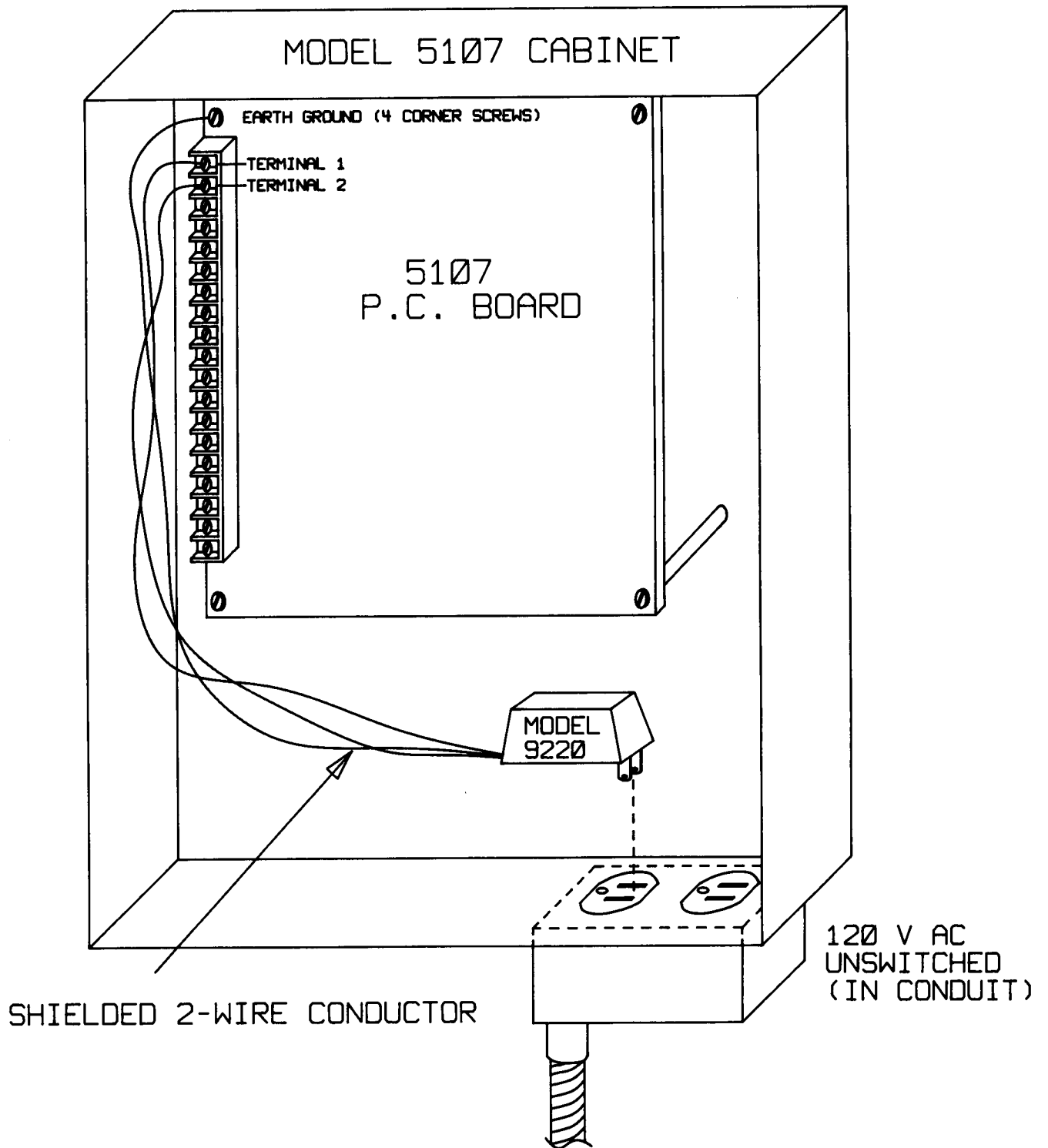

FIGURE 2

6.4 BATTERY CABLES

The RED (+) and BLACK (-) battery cables are used for connection to a 6-AH 12-V battery (Silent Knight Model 6712), which will provide a minimum of 24 hours of backup power to the Model 5107 if an interruption should occur in the AC line power to the system.

Use the following formula to verify the number of standby hours provided:

$$H = \left[\frac{AH}{I} \right] \times 0.65$$

WHERE: H = Standby hours.
AH = Ampere-hour rating of battery.
I = Standby current.
0.65 = A constant used to derate the battery to assure a 5-year life.

*NOTE: The Model 6712 12V 6-AH battery provides over 24 hours of standby operation to the **basic** 5107 system. The use of accessories may reduce the standby time so that additional battery capacity may be needed to meet the 24 hour UL requirement.*

CAUTION: To prevent damage to the 5107, make sure that proper polarity is being observed when the battery cables are being connected.

6.5 POWER LIGHT

The green power light is normally on and will remain on unless one or more of the following conditions occur:

- * AC power is removed from the 5107.
- * Fuse F2 or F3 (non replaceable) is open.
- * The Fire Reset switch is being pressed.

6.6 AUDIBLE TROUBLE SIGNAL SILENCED LIGHT

The red Audible Trouble Signal Silenced Light is normally off and will remain off unless the Audible Trouble Signal has been silenced by the Audible Trouble Signal Speaker Switch. Once this light is on, it will remain on until the trouble has been resolved.

6.7 FIRE RESET/AUDIBLE TROUBLE SIGNAL SPEAKER SWITCH

This switch has two functions. One is to silence the Audible Trouble Signal which will sound if one or more of the supervised loops becomes defective. When you do this the red "Audible Trouble Signal Silenced Light" is turned on and remains on until the trouble is resolved. The other function of this switch is Fire Reset, which momentarily removes power from terminal 33 which will reset the smoke detectors.

6.8 FUSES

F1 is a 1-1/2 Amp Fast Blow Fuse which provides over-current protection for any accessories connected to terminal 32 of the 5107. F2 is a 1/2 Amp Fast Blow Fuse which provides over-current protection for the smoke detectors and any other accessories attached to terminal 33 of the 5107. F4 is a 5A fuse which provides protection for the 5107 in case the battery is improperly installed.

6.9 EEPROM (Electrically Erasable Programmable Read Only Memory)

The model 5107 Control/Communicator uses an EEPROM memory chip to store programming information such as telephone numbers, reporting format, account

number and information regarding options. All these functions must be programmed into the EEPROM either by using the model 5506 Desk Top Programmer or the Model 5510 Hand Held Programmer. For more information, look in the programming section.

6.10 DIALER TEST SWITCH

By depressing this switch the 5107 will automatically dial the Central Station and report a test code.

6.11 JUMPER WIRE

Refer to Figure 1 for the location of the following jumpers.

J1 - **Ground Fault Detection Jumper**: This jumper is left in place to enable the 5107 to detect ground faults in Class A zones. If this jumper is removed or cut the 5107 will not detect a ground fault in these zones.

J2 - DO NOT CUT

J3 - Bell Supervision Jumper. This jumper is left in place to enable the Supervised Bell circuit. Cut this jumper if you are not using a supervised bell.

6.12 PLUG-ON CONNECTOR

Plug-on connector P4 is used to connect the Model 5108 Annunciator Control Board. This board is used with the Model 5118 8 Zone Annunciator.

7 DESCRIPTIONS OF FEATURES

7.1 CLASS A FIRE LOOP

The 5107 features 2 Class A fire zones. Each Class A Fire zone is a four wire circuit which allows an alarm to be detected even after a single open or ground fault occurs (see figure 5). A single open or ground fault will cause the audible trouble signal to sound and the 5107 will report the trouble to the central station. Use only Normally Open initiating devices for these zones. The Class A zones are zones 1 and 2. Additional Class A zones may be formed by adding model 7171 Class A Loop Monitors to Class B zones as shown in Figure 10. Any Class B zone input of the 5107 may be used. All wiring between the 7171 modules and the 5107 should be enclosed in conduit.

7.2 CLASS B FIRE LOOP

Zones 3 through 8 on the 5107 are Class B Fire Zones. Each Class B zone consists of a two wire circuit which will detect the occurrence of an open in the loop but may not be able to detect an alarm after such an occurrence (see figure 2). The detection of an open will cause the audible trouble signal to sound and the 5107 will report the trouble to the central station. Use only Normally Open initiating devices for these zones.

NOTE 1: For the purpose of this manual, a normally open device is one whose contacts conduct when in the alarm condition and do not conduct in the non-alarm condition.

NOTE 2: You may not use Zone 8 as an Alarm input if you are using the supervised bell circuit but you still must install the end-of-line resistor.

7.3 PHONE LINE MONITORS

A dual phone line monitoring function has been built into the model 5107. If a problem should be detected in a telephone line, an audible trouble signal will be sounded. The trouble will also be reported to the central station over the other phone line, which should still be working. There is a delay of approximately 45 seconds before a line fault that is being detected is reported as trouble. The phone line monitoring function will therefore not attract attention to malfunctions or glitches in the phone line which are quickly restored.

7.4 AUTOMATIC SELF TEST

The model 5107 contains a self test circuit. Through this circuit, the model 5107 Control/Communicator automatically tests itself and the telephone line which connects it to the central station. This testing takes place at a predetermined time every day. The self test time is set through the membrane keypad on the 5107.

The 5107 has a clock circuit which is crystal controlled. This clock circuit keeps on working even if AC power should be interrupted. The clock is controlled from the membrane keypad.

The self test can also be manually controlled. This is accomplished by pressing the Dialer Test switch. This procedure causes the model 5107 to report a test code to the central station.

7.5 ADDITIONAL TROUBLE REPORTING

In addition to the trouble conditions already discussed, a low battery or a loss of AC power condition will also sound the audible trouble signal and cause the 5107 to report the trouble to the central station. The backup battery of the unit is continuously being charged and monitored to insure that it is in good condition. If a loss of AC is detected, it will be reported and the backup battery will supply power to the unit.

7.6 WATCH-DOG CIRCUIT

During normal operation, the microprocessor of the 5107 is constantly running its program to check inputs and carry out other routine functions. If for some reason this program stops running, the watch-dog circuit will automatically detect this and attempt to resume normal operation by resetting the microprocessor. Each time the watch-dog circuit initiates a reset signal it will also sound the audible trouble signal for a short beep.

8 MODEL 5107 REPORTING FORMATS

The 5107 can transmit information in three different formats. The format you choose depends on the type of receiver used at the central station. The three formats available are:

- * SILENT KNIGHT FSK - high speed, single round format, for use with Silent Knight Models 8510, 8520, or 9000 receivers.
- * RADIONICS HEX - format for use with Radionics or updated Ademco receivers.
- * EXPANDED RADIONICS HEX - format for use with Radionics receivers.

8.1 MODEL 9000 RECEIVER DATA USING SK FSK

The following table shows how the Model 9000 receiver prints out the various codes from the 5107 when using the FSK 4/2 format.

CODE	EVENT	9000 PRINT OUT
01	ALARM ZONE 1	ALARM 01
02	ALARM ZONE 2	ALARM 02
03	ALARM ZONE 3	ALARM 03
04	ALARM ZONE 4	ALARM 04
05	ALARM ZONE 5	ALARM 05
06	ALARM ZONE 6	ALARM 06
07	ALARM ZONE 7	ALARM 07
08	ALARM ZONE 8	ALARM 08
21	ALARM RESTORE ZONE 1	RESTORE ALARM 11
22	ALARM RESTORE ZONE 2	RESTORE ALARM 12
23	ALARM RESTORE ZONE 3	RESTORE ALARM 13
24	ALARM RESTORE ZONE 4	RESTORE ALARM 14
25	ALARM RESTORE ZONE 5	RESTORE ALARM 15
26	ALARM RESTORE ZONE 6	RESTORE ALARM 16
27	ALARM RESTORE ZONE 7	RESTORE ALARM 17
28	ALARM RESTORE ZONE 8	RESTORE ALARM 18
30	DIALER TEST	TEST 30
31	PHONE LINE FAULT	PHONE TROUBLE 01
33	EARTH GROUND FAULT	EXPANSION TROUBLE 33
35	PHONE LINE RESTORE	PHONE RESTORE 01
37	EARTH GROUND RESTORE	EXPANSION RESTORE 37
60	LOSS OF AC	AC TROUBLE 60
61	TROUBLE ZONE 1	TROUBLE 01
62	TROUBLE ZONE 2	TROUBLE 02
63	TROUBLE ZONE 3	TROUBLE 03
64	TROUBLE ZONE 4	TROUBLE 04
65	TROUBLE ZONE 5	TROUBLE 05
66	TROUBLE ZONE 6	TROUBLE 06
67	TROUBLE ZONE 7	TROUBLE 07
68	TROUBLE ZONE 8	TROUBLE 08
69	LOW BATTERY	LOW BATTERY 69
70	AC POWER RESTORED	AC RESTORE 70
71	TROUBLE RESTORE ZONE 1	RESTORE ALARM 01
72	TROUBLE RESTORE ZONE 2	RESTORE ALARM 02
73	TROUBLE RESTORE ZONE 3	RESTORE ALARM 03
74	TROUBLE RESTORE ZONE 4	RESTORE ALARM 04
75	TROUBLE RESTORE ZONE 5	RESTORE ALARM 05
76	TROUBLE RESTORE ZONE 6	RESTORE ALARM 06
77	TROUBLE RESTORE ZONE 7	RESTORE ALARM 07
78	TROUBLE RESTORE ZONE 8	RESTORE ALARM 08
79	BATTERY TROUBLE RESTORE	BATTERY RESTORE 79

8.2 SILENT KNIGHT FSK FORMAT

The Silent Knight FSK format transmits a four digit account number and a two digit alarm code.

<u>TWO DIGIT ALARM CODE</u>	<u>DESCRIPTION</u>
00	NOT USED
01-08	ZONES 1-8 RESPECTIVELY ARE IN ALARM (*1)
09-20	NOT USED
21-28	ZONES 1-8 RESPECTIVELY HAVE BEEN RESTORED TO NORMAL, FROM AN ALARM CONDITION.
29	NOT USED
30	DIALER TEST
31	PHONE LINE FAULT
32	NOT USED
33	EARTH GROUND FAULT
34	NOT USED
35	RESTORATION OF PHONE LINE FAULT
36	NOT USED
37	RESTORATION OF EARTH GROUND FAULT
38-59	NOT USED
60	LOSS OF AC (*1)
61-68	ZONES 1-8 RESPECTIVELY ARE IN TROUBLE, SUPERVISED LOOP HAS BEEN BROKEN (*1)
69	LOW BATTERY VOLTAGE (*1)
70	AC POWER RESTORED
71-78	ZONES 1-8 RESPECTIVELY HAVE BEEN RESTORED TO NORMAL, FROM A TROUBLE CONDITION.
79	BATTERY VOLTAGE RESTORED
80-99	NOT USED

*1 - REPORT MEMORY: Report memory is an option that is selected when programming the EEPROM (see Prom Coding Form). When report memory is selected, an alarm or a trouble condition in any of the eight zones or two power sources will be remembered and re-reported along with other new conditions until they are restored. All other events are reported only once.

8.3 RADIONICS HEX FORMAT

When using a Radionics or Ademco receiver you must select the Radionics Hex format on the Prom Coding Form. When you have selected this format, the 5107 will translate the Silent Knight two digit codes into data that these receivers will recognize. An EXPANDED HEX format option allows the use of all 8 alarm zones when reporting to a Radionics receiver. Only the normal HEX format can be decoded by an Ademco receiver. The following chart shows what will be displayed at either receiver for each of the corresponding two digit Silent Knight codes. The Radionics receiver will display a three digit account code and an English message. The Ademco receiver displays alarms as a single digit code along with the three digit account number. All other events are displayed as 8 channels plus a status channel on the Ademco receiver.

8.4 SK TO RADIONICS & ADEMCO CONVERSION TABLE

SK 2-DIGIT CODE	RADIONICS RECEIVER	RADIONICS RECEIVER	ADEMCO RECEIVER
	EXPANDED HEX FORMAT	NORMAL FORMAT	NORMAL HEX FORMAT
01-08	ALARM ZONE 1-8 (RESPECTIVELY)	ALARM ZONE 1-5 (RESPECTIVELY)	1-5 (ALARMS DISPLAYED AS 1 DIGIT CODE)
21-28	RESTORE ZONE 1-8 (RESPECTIVELY)	RESTORE ZONE 1-5 (RESPECTIVELY)	3555 5555 7 (ZONE 1 RESTORE SHOWN)
30 TEST	RESTORE ZONE 9	RESTORE ZONE 9	5555 5555 B
31	TROUBLE ZONE B	TROUBLE ZONE 7	5555 5505 7 (TROUBLE ZONE 7)
33	TROUBLE ZONE C	TROUBLE ZONE 8	5555 5550 7 (TROUBLE ZONE 8)
35	RESTORE ZONE B	RESTORE ZONE 7	5555 5535 7 (RESTORE ZONE 7)
37	RESTORE ZONE C	RESTORE ZONE 8	5555 5553 7 (RESTORE ZONE 8)
60	TROUBLE ZONE 0	TROUBLE ZONE 6	5555 5055 7 (TROUBLE ZONE 6)
61-68	TROUBLE ZONE 1-8 (RESPECTIVELY)	TROUBLE ZONE 1-5 (RESPECTIVELY)	0555 5555 7 (TROUBLE ZONE 1 SHOWN)
69	TROUBLE ZONE 9	TROUBLE ZONE 9	5555 5555 8 (LOW BATTERY)
70	RESTORE ZONE 0	RESTORE ZONE 6	5555 5355 7 (RESTORE ZONE 6)
71-78	RESTORE ZONE 1-8 (RESPECTIVELY)	RESTORE ZONE 1-5 (RESPECTIVELY)	3555 5555 5 (RESTORE TROUBLE Z1 SHOWN)
79	RESTORE ZONE 9 (SAME AS TEST)	RESTORE ZONE 9 (SAME AS TEST)	5555 5555 B (SAME AS TEST)

9 PROGRAMMING

You need to select options which must be programmed into the EEPROM (Electrically Programmable Read Only Memory). The EEPROM is an eight pin Integrated Circuit Chip which can be reprogrammed whenever you need to change some part of the program.

The Prom Coding Form (provided) explains each option. By programming this information, you may customize the model 5107 to meet the special needs of your customer.

The model 5506 Desk Top Programmer or the model 5510 Hand Held Programmer can be used to program the EEPROM. Consult the operation manual of the programmer and the Prom Coding Form to program the PROM. The model 5107 is shipped with the EEPROM inserted into its socket in the printed circuit board (See Figure 1). The EEPROM must be removed and programmed before the 5107 control panel can be installed (See PROM removal below).

If you should wish to use the model 5506 programmer, it must contain revision 8503-1 software or software of later revisions. If your programmer should contain older software, you should contact the Technical Services Department to have it updated.

The sockets of both programmers are designed for IC's with 16 pins. It is important that the EEPROM is inserted into the correct half of the programmer socket (See the figure below). Pin 1 of the PROM should be inserted into the lower left hole of the programmer socket.

When you are using the model 5506 programmer, always use socket #1 to prevent damage to the PROM. After the PROM has been programmed, it should be removed from the programmer socket and reinserted into its socket on the model 5107 PC Board (See PROM insertion below).

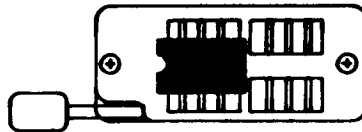

9.1 PROM REMOVAL

In order to remove the EEPROM from its socket on the PC board, pull it carefully straight out. A small flat blade screwdriver can be used to gently lever the PROM out of its socket. Slip the screwdriver under one end of the PROM and pry it up slightly. Then place the screwdriver under the other end and finish the removal procedure.

9.2 PROM INSERTION

To insert the PROM back into its socket on the 5107 PC Board, carefully press the PROM into its socket. Pay careful attention to which way the notch cut-out of the PROM is facing. It should be on the right side if the board is oriented as shown in figure 1. Apply even pressure on each end of the PROM so that it goes in squarely.

9.3 PROM PROGRAMMERS

9.3.1 MODEL 5506

Plug in the AC power cord
Turn on the POWER switch.

Display shows: "HELLO"

Press "ENTER"

Display shows: 0---0

You are now in step "0" and ready to start programming.

Step 0: Enter "5107"

Press "ENTER"

Display shows: 15107

If the step number did not change to "1", then either you entered the model number incorrectly or your programmer cannot program the model 5107. If the later case, contact the factory and we will send the correct software.

Step 1: This is an unused file location for your own use. It can hold a four digit number

Press: "ENTER".

Display shows: 2---1

Continue programming Steps 2 through 11 using the data as entered in the PROGRAM CODING FORM for the 5107.

After completing Step 11 the display will show "05107".

You are now ready to program the PROM. Be sure there are NO PROM'S in any of the sockets.

Press the "PROGRAM" key.

Display shows: "CHIP 1"

Place the handle of the PROM socket "1" in the raised position.

Insert the PROM into the socket, making sure that the notch of the PROM faces toward the handle.

Close the socket by moving the handle down until it locks.

Press the "PROGRAM" key.

The display will either show "PASS or FAIL".

"FAIL" indicates that either the PROM was inserted incorrectly, no PROM was inserted or the PROM is defective.

CAUTION: Always program the PROM with the program in step "0"

Additional PROM'S may now be programmed.

NOTE: If incorrect data is programmed into the PROM or if in the future, the option requirements change, this PROM can be reprogrammed up to 1000 times.

9.3.2 MODEL 5510

Press the "ON" key.

Display shows: "HELLO"

Press the "ENTER" key.

Display shows: 0---0

You are now in the Step 0. Proceed exactly as directed for the Model 5506.

9.4 PROM CODING FORM FOR THE MODEL 5107 CONTROL/DIALER CHIP

Programmer Requirements: Model 5506 with revision 8503-1 or later software
 Model 5510 with revision 8503-1 or later software

Prom type: Electrically Erasable (8-pin) x2443 or x2444

STEP	DATA	DEFAULT	RANGE	DESCRIPTION
0	5107			
1	— — — — 5107	0-9999		Optional file # for your own use.
2	— — 1	1-15		Number of attempts before switching phone numbers.
3	— — 10	5-10		Total number of attempts to be made (combined totals).
4	— — 8	1-15		Number of hours before AC Power Loss is reported.
5	— — 2	1-4		Waterflow switch detection delay 1 = .03 - .04 seconds 2 = 3 - 4 seconds 3 = 30 - 40 seconds 4 = 60 -80 seconds

NOTE: If switches with built in delays are used, choose a value of 2 for Steps 5. Only Zones 1 and 2 are affected by this delay.

There are seven (7) selections to be made in step 6. Circle the digits (1-8) next to the options you DO want. The programmer will display only those options that are selected (see note 3). An (N) in the default column indicates that the option is not selected by default. A (Y) indicates that the option is selected by default.

NOTE: Starting with software Model 9091, Revision B, you must select at least one of the first two options of step 6. Failure to do so may cause the 5107 to call the receiver without having any valid data to send, which would cause a false alarm. If you are using this software revision, be sure to use the PROM coding form with P/N 150503. (The earlier part number was 150295.)

STEP	DATA	DEFAULT	DESCRIPTION
6.1	1 Y		Report restores troubles, and tests to phone number 1.
6.2	2 Y		Report restores, troubles and tests to phone number 2.
6.3	3 N		Expanded Radionics Format (see note 4) (applies to both phone numbers)
6.4	4 Y		Can call phone number 2.
6.5	5 Y		Must call phone number 1.
6.6	6 N		Must call phone number 2 (also select 6.4)
6.7	7 NOT USED		
6.8	8 Y		Report Memory (old events) (applies to both phone numbers)

There are (8) selections to be made in step 7. Circle the digits (1-8) next to the options you DO want. The programmer will display only those options that are selected.

STEP	DATA	DEFAULT	DESCRIPTION
7.1	1	N	Phone number one is touchtone. (if N then phone #1 is rotary dial)
7.2	2	N	Phone number one is 2300Hz acknowledge. (if N then phone #1 is 1400Hz acknowledge)
7.3	3	N	Phone number one is Radionics hex data. (if N then phone #1 is Silent Knight FSK)
7.4	4	N	Not used.
7.5	5	N	Phone number two is touchtone. (if N then phone #2 is rotary dial)
7.6	6	N	Phone number two is 2300Hz acknowledge (if N then phone #2 is 1400Hz acknowledge)
7.7	7	N	Phone number two is Radionics hex data. (if N then phone #2 is Silent Knight FSK)
7.8	8	N	Not used.

Steps 8 and 9 contain the two account numbers. Only the Silent Knight format uses all four digits. The Radionics format will ignore the left hand digit. If using the Radionics format, you must enter an "A" in the place of any "O's". Entering a "0" will Print as a blank on the Radionics receiver.

NOTE: You must enter leading "0's" if the account number has less than four digits.

8	----	Account number one (for phone number one)
9	----	Account number two (for phone number two)
10	---- ---- ---- ----	Phone number one.
11	---- ---- ---- ----	Phone number two.

IMPORTANT INFORMATION CONCERNING THE PROGRAMMING OF THE MODEL 5107 CONTROL/DIALER CHIP.

- 1) When using the Model 5506 programmer, insert prom in socket #1. Be sure the notched end of the prom (indicating pin 1) is to the left when inserted in socket #1 of the programmer.
- 2) The DATA column of the prom coding form is where you enter or select the information to be programmed.

The DEFAULT column of the prom form shows the information that the programmer normally contains in its ROM. If you change nothing in a step, this is what will be programmed into the prom.

The RANGE column of the prom form shows the minimum and maximum possible values that may be used for that step.

- 3) When programming steps (6) and (7) be aware that the programmer can only display (4) digits at a time. In order to display all digits the programmer will alternate its display between the first (4) and last (4) digits. If you do not want a specific feature or option, be sure that the digit associated with that feature or option is not displayed.
- 4) If N is selected in step 6.3 and either phone reports in the Radionics format, then zones 6, 7 and 8 CANNOT be used for alarm reporting. Instead, low AC will report as zone 7, and earth ground fault will report as zone 8.

Note: You must select (N) in step 6.3 if reporting to an Ademco receiver.

If the 5107 reports to a Radionics receiver then you may select (Y) in step 6.3 and you may use all 8 zones. In this case, low AC will report as zone 0, the phone line monitors will report as zone B, and earth ground fault will report as zone C.

9.5 HOW TO SET THE AUTOMATIC SELF TEST TIME

When power is applied to the 5107 the clock display is in the Real Time Display Mode. This is the normal operating mode of the display. Use the switches labeled "HOURS" and "MIN." (Minutes) to set the Real Time. Note that there is an AM/PM symbol on the left side of the display. To set the automatic self test time you must **press and hold** the "TEST TIME" switch while setting the hours and minutes. Note that when you are setting the Test Time an "AL" symbol will appear on the right side of the display to indicate that you are setting the automatic self test time. If when setting either the real time or alarm time, the two times are the same, the control panel will report a test. The control panel will now report a test every day at the test time selected.

10 5107 CONTROL PANEL INSTALLATION

10.1 SELECT A LOCATION

When selecting a location to mount the 5107 control panel consider the following factors. The unit should be mounted where it will not be exposed to extremes in temperature and it will be free from moisture. The panel should be accessible to "Main Drop" wiring runs. The 5107 should be located well within a secured area but should be accessible for testing and service.

10.2 MOUNT THE 5107

When mounting on interior walls use appropriate screw anchors in plaster. When mounting on concrete, especially when moisture is expected, attach a piece of 3/4 inch plywood to the concrete surface and then attach the 5107. Mount any other desired components (such as optional 7171 modules) to the plywood interface.

10.3 INSTALL THE 9220 POWER TRANSFORMER

Figure 3 shows the connection of the Model 7890 Transient-Surge Protector to the Model 9220 UL Listed Class II Power Transformer (16.5 VAC 45VA). The transformer should be plugged into the 120 VAC 60 Hz. continuous duty (unswitched) grounded outlet mounted to the bottom of the 5107 cabinet as shown in Figure 2.

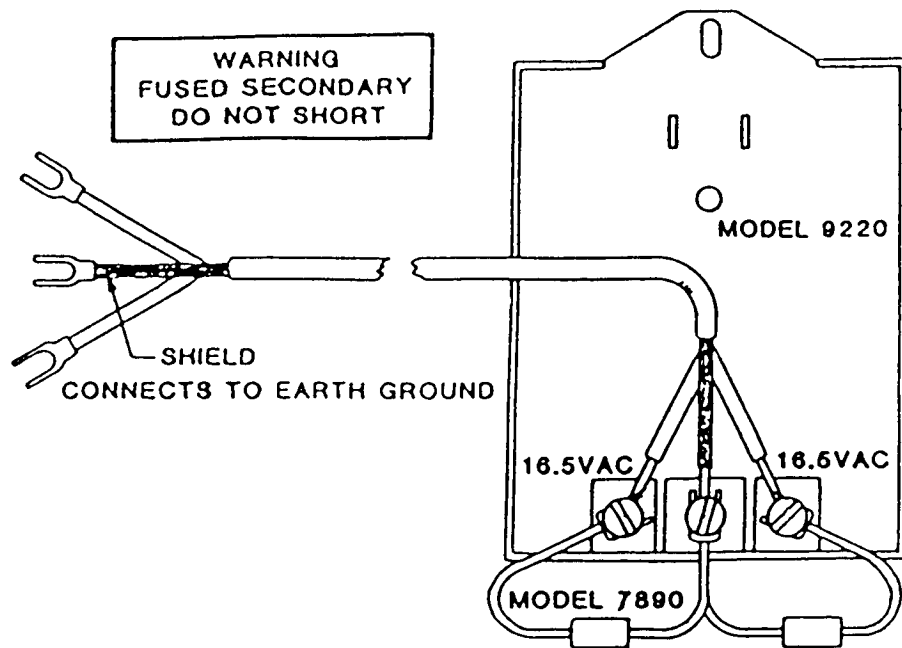

MODEL 9220 POWER TRANSFORMER

FIGURE 3

WARNING: The Model 9220 contains an internally fused secondary winding. DO NOT SHORT the secondary terminals together when power is applied or the internal fuse will blow. Be sure the shield conductor can not come in contact with the AC output screws.

The model 7890 Transient Surge Protector will clamp the AC output of the transformer. This reduces the transient voltages that may be caused by lightning and other sources. The AC power lines are among the most common sources of transient voltage and lightning damage in alarm systems. The Model 7890 is composed of two bipolar transient suppressors with that are equipped with lugs at its connecting points.

WARNING: Before you connecting the transformer, you must verify that the center mounting screw in the AC wall plate is grounded to earth ground. This can be determined by measuring the AC voltage between the mounting screw and each side of the AC line. There must be approximately 117 VAC between the screw and one side of the outlet, and 0 VAC between the screw and the other side of the outlet. If these voltages are not found to be present, the outlet does not have earth ground. It must then be grounded by running a 16 gauge wire from the outlet to a good ground. The ground could for example be a cold water pipe.

CAUTION: To reduce the risk of fire or electrical shock, connect directly to a grounded (3-prong) receptacle.

10.4 CONNECT ALL INITIATING DEVICES AND ACCESSORIES

Connect all initiating devices and accessories to the 5107 terminal strips before connecting AC or DC power to the panel. Use the wiring diagram in Figure 10 and the terminal strip description as a guide.

10.5 CONNECT POWER TO THE 5107

Make sure the EEPROM has been programmed and reinstalled into the 5107 circuit board before continuing (see programming section). Connect the battery cables to the lugs on the backup battery, pay attention to the polarity of the batteries (black to the - terminals, red to the + terminals). Verify that the system is operational before continuing. If the system is not operational suspect the backup battery, poor connections or battery polarity. Connect the two conductor cable from the Model 9220 transformer to terminals 1 and 2 on the control panel terminal strip.

NOTE 1: Panel should begin operating as soon as either power source is connected. Powering up the panel with the Battery first may cause the panel to report an AC power loss.

NOTE 2: When installing a 5107 with a battery that is not fully charged, a short "beep" (less than 0.1 seconds) may be heard during the battery test. This sound will continue to be emitted until the battery is completely charged.

11 ZONE WIRING

11.1 MODEL 7620 UL LISTED SMOKE DETECTOR

In the following sample wiring diagrams, the Model 7620 listed smoke detector is used. As illustrated in figure 4, the black and red wires of the 7620 are used to provide the +12 VDC input power and the White/ Violet and Violet wires provided the normally open alarm contacts. Smoke detector power should come from terminal 33. To reset smoke detectors, power must be removed for approximately 2 seconds.

FIGURE 4

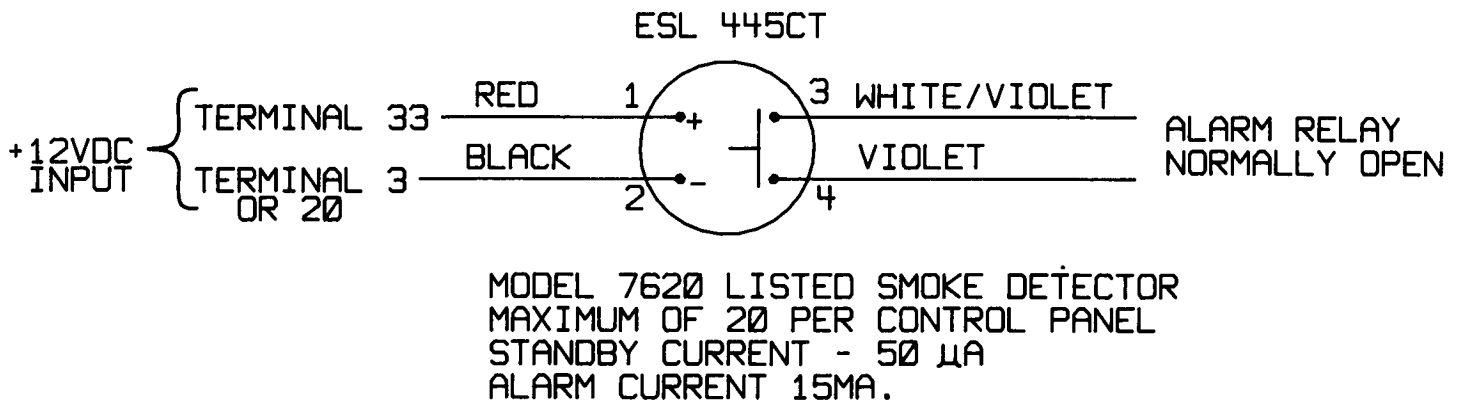

11.2 CLASS A ZONES

Zones 1 and 2 are Class A fire zones. No End-of-Line resistors are needed for these zones. Zone 1 inputs are wired into terminals 10, 11, 12 and 13 as shown in the example in figure 5. Zone 2 inputs are wired into terminals 14, 15, 16, and 17. One should only use normally open detector or sensors for these zones. Maximum loop resistance should not exceed 100 Ohms. There should be no more than 5 sensors or detectors on each zone.

FIGURE 5

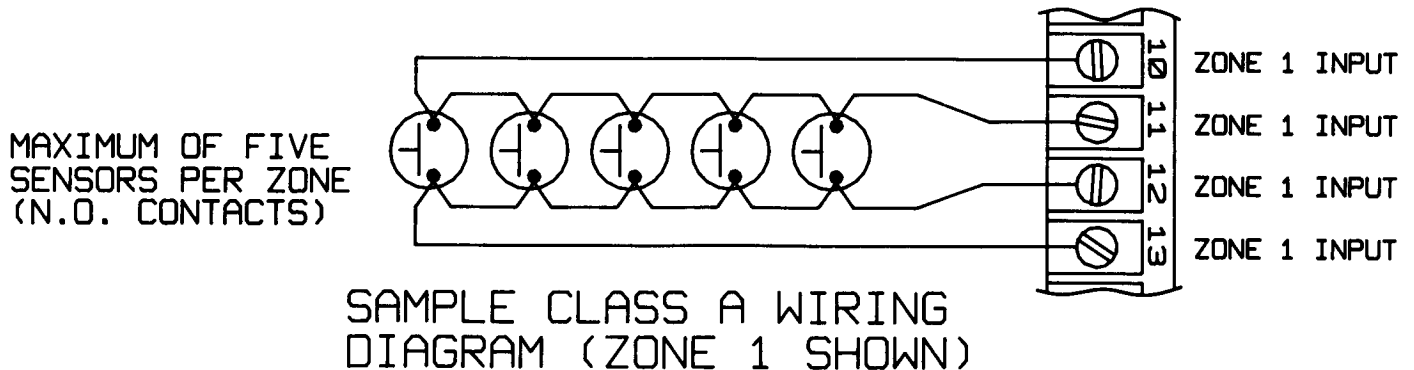

11.3 POWER SUPERVISION UNIT

An ESL 204A power supervision unit is required in UL listed installations that use 4 wire smoke detectors. The reason is that if a break should occur in the ground wire, the smoke detector might become inoperative without sending a trouble signal to the model 5107 Control/Communicator.

11.4 CLASS B ZONES

Zones 3 through 8 are Class B fire zones. One side of each Class B loop will connect to a zone input terminal (see figure 11 for terminal strip designations), and the other side of each loop will connect to loop power or smoke detector power. Each Class B loop must employ a Model 7630 15K End-of-Line resistor wired in series with the loop and in parallel with the Normally Open contacts farthest from the panel. See figure 6 for a sample wiring diagram.

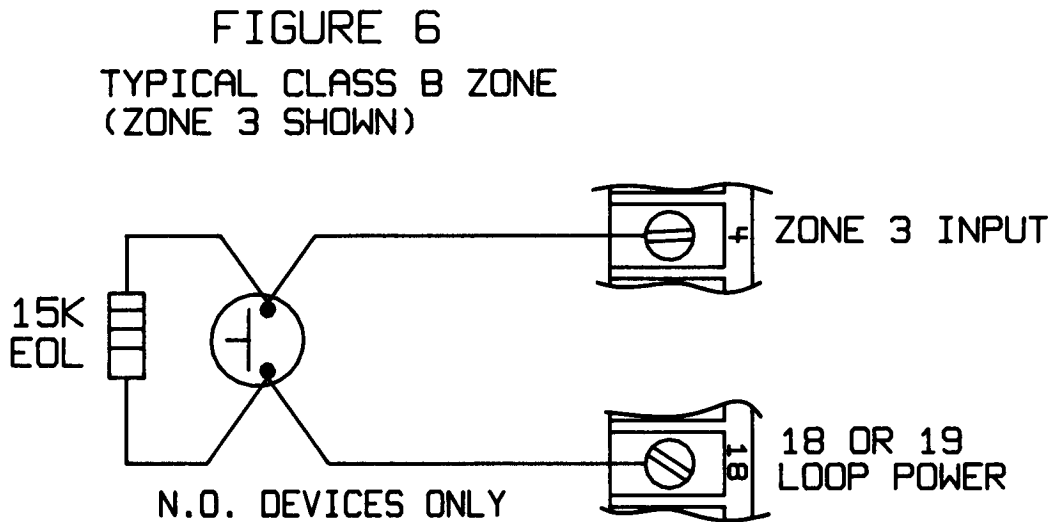

12 TELEPHONE WIRING

12.1 DUAL TELEPHONE LINES

The 5107 connects to two separate telephone lines to report data to the central station. An RJ31X type jack should be installed by the telephone company for each line. Two Model 7860 connecting cords will mate to the RJ31X jacks. The opposite end of one of these cords is wired into terminals 28, 29, 30 and 31 of the 5107 and is telephone line #1. The other connecting cord is wired into terminals 24, 25, 26 and 27 of the 5107 and is phone line #2. Refer to Figure 7 and the terminal strip designation for proper installation.

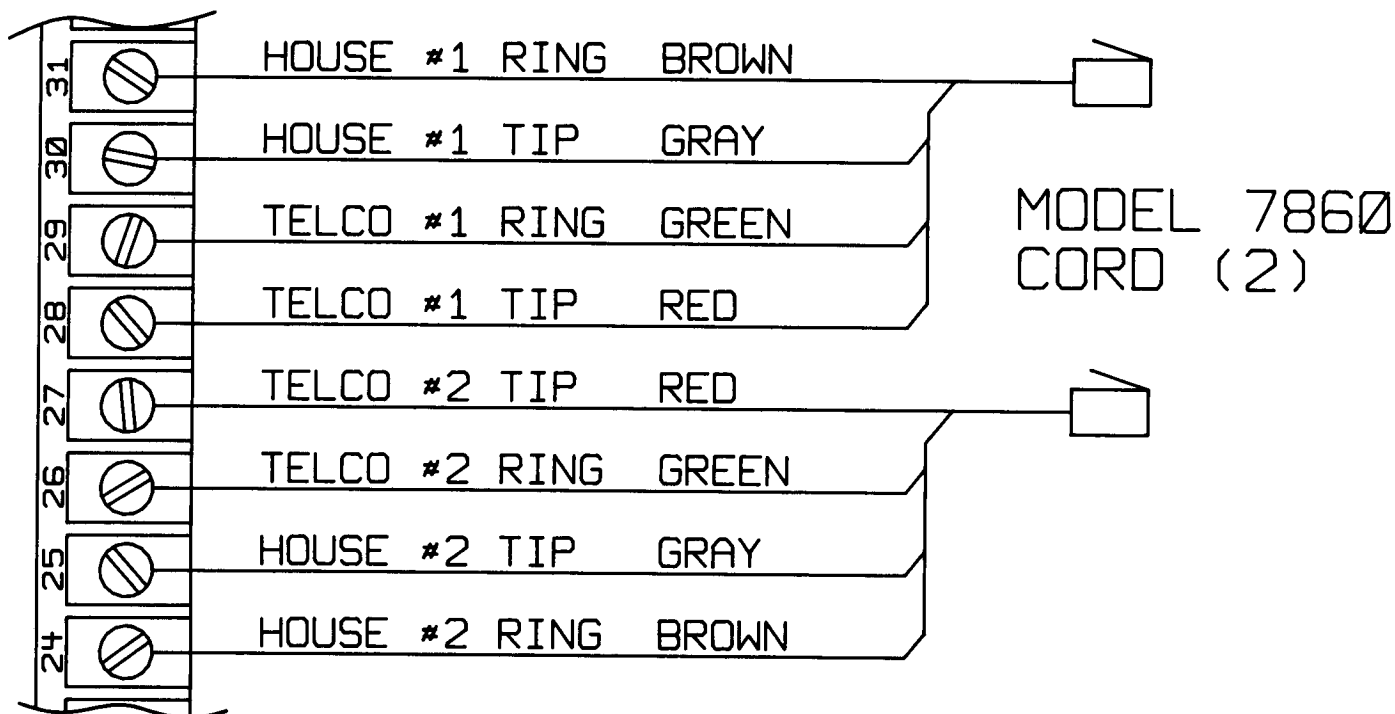

FIGURE 7
TELEPHONE WIRING

13 ACCESSORY WIRING

13.1 SUPERVISED ALARM BELL

WARNING: If you will be using the Supervised Bell circuit, you CANNOT use zone 8 as an Alarm input. If you wish to use Zone 8 as an Alarm input, you MUST cut Jumper J3 to disable the Supervised Bell circuit.

A 12 VDC supplementary alarm bell may be wired into the 5107 between terminal 21 (bell +) and terminal 22 (bell -). The only accepted bell is a Wheelock Model 46TG10. Use of any other device may cause harmful interference. Install the supplied surge protector (Model 7893) directly across the contacts of the bell. To use the Supervision Circuit, a polarized bell must be used. The UL approved bell is the Wheelock Model 46TG10 12VDC CP. Refer to Figure 8 for wiring. The maximum output load on terminal 23 (Bell) is 350 mA. A 15K EOL must be used for bell supervision. To inhibit bell supervision, Cut Jumper J3 on the PC board.

FIGURE 8
SUPERVISED BELL WIRING

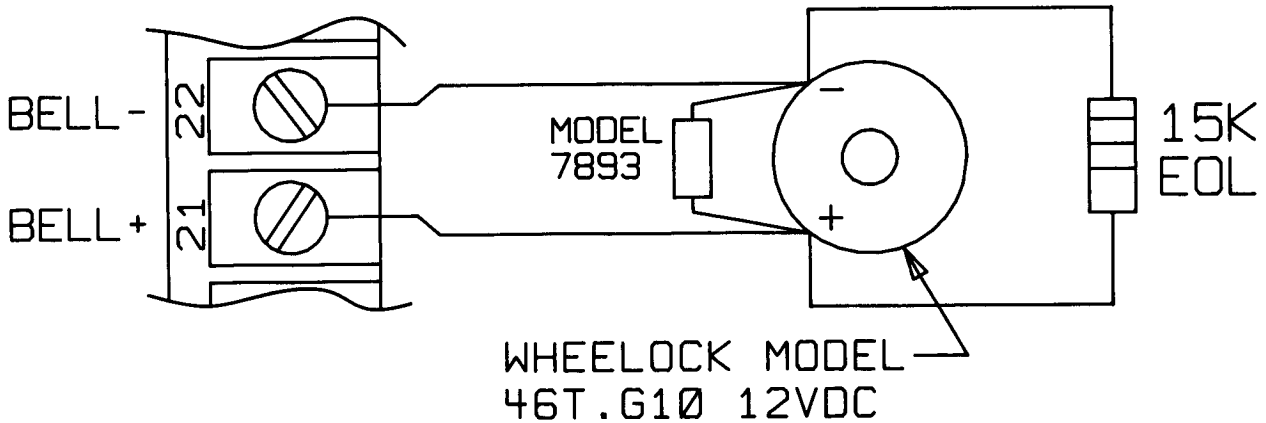

13.2 CONNECTION TO THE MODEL 7171 4-WIRE-LOOP MODULE

Through the use of a Model 7171 module you can convert one of the Class B zones of the 5107 into a Class A zone. One module is required for each additional Class A zone needed. Figure 9 illustrates the proper method of wiring the 7171 module to the 5107 control panel.

FIGURE 9

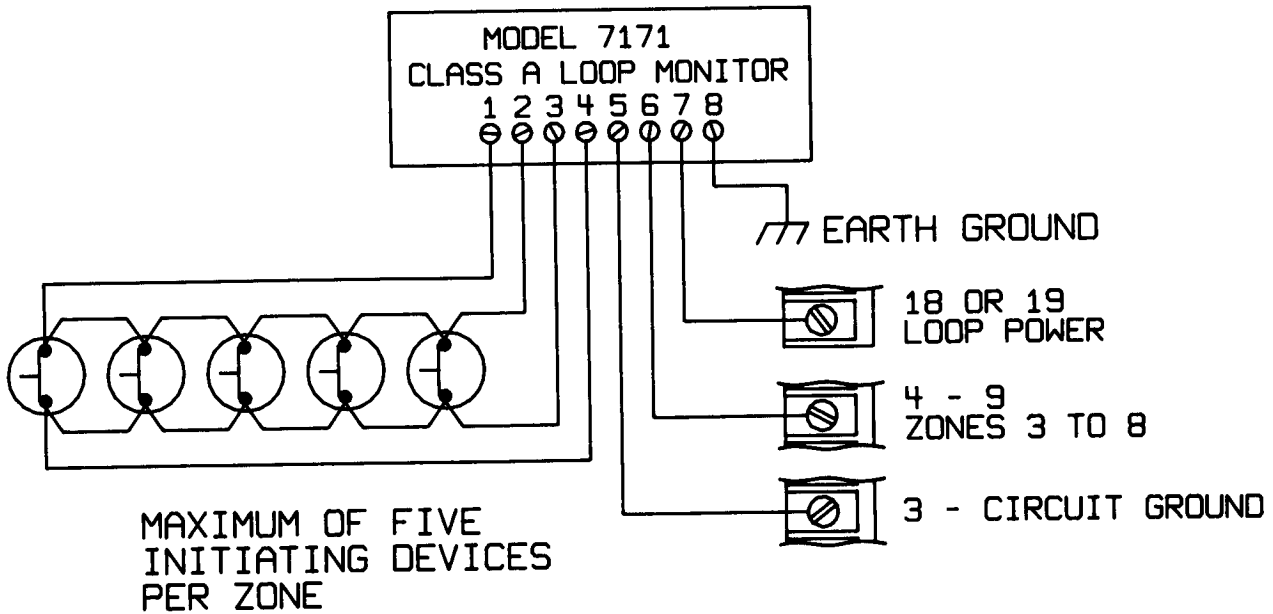
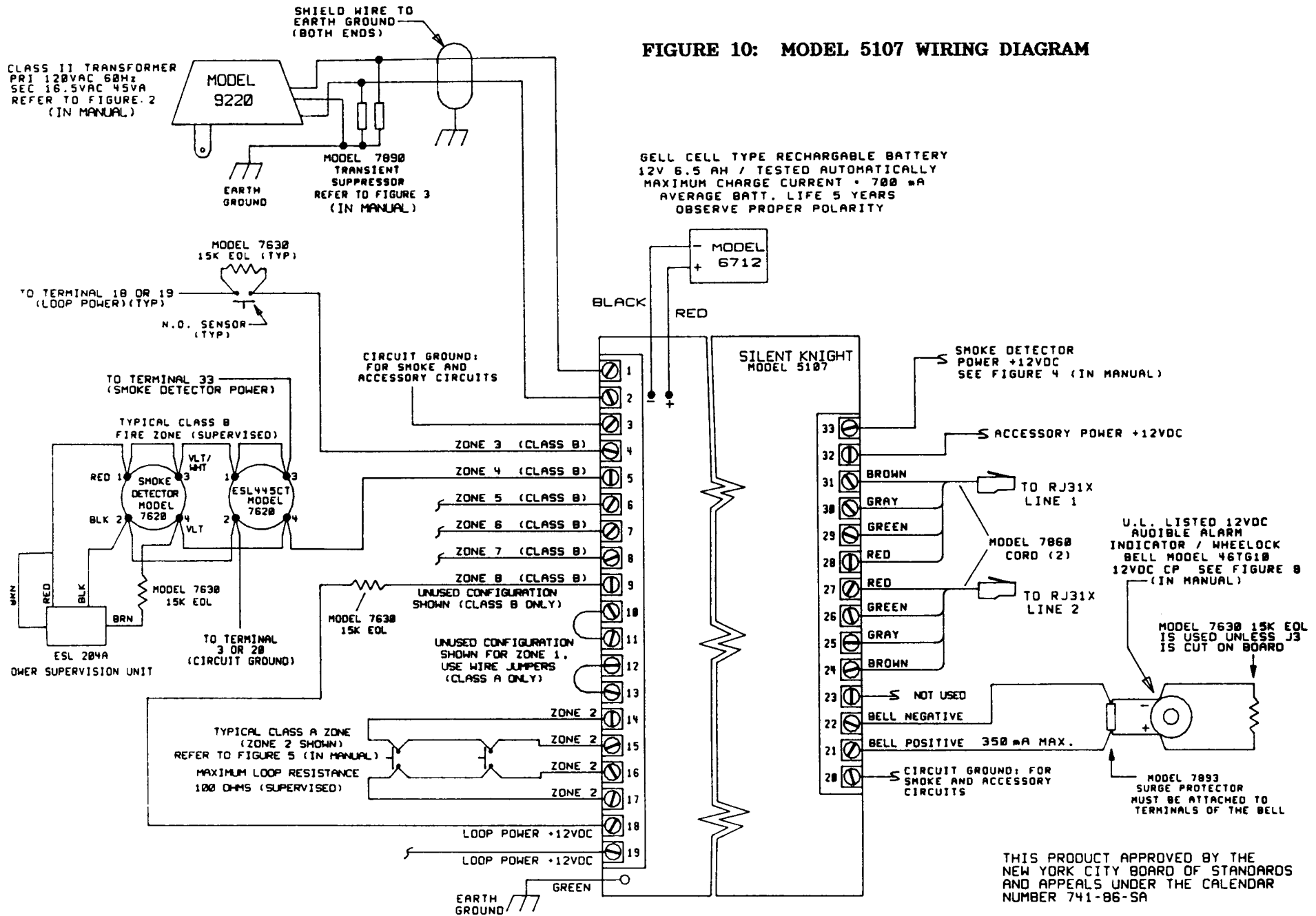

FIGURE 10: MODEL 5107 WIRING DIAGRAM



24

Revised 4/90

'This equipment complies with the requirements for a class A computing Device in FCC Rules Part 15 Subpart J. Operation of this device in a residential area may cause harmful interference requiring the user to take whatever steps may be necessary to correct this interference.'

ALL CIRCUITS ARE INHERENTLY POWER LIMITED

COMPLIES WITH PARTS 15 AND 68 FCC RULES
 FCC REGISTRATION NO. AC698R-68913-AL-E
 RINGER EQUIVALENCE - 0.00
 TELEPHONE JACK NO. RJ31X
 MADE IN USA

THIS PRODUCT APPROVED BY THE NEW YORK CITY BOARD OF STANDARDS AND APPEALS UNDER THE CALENDAR NUMBER 741-86-SA

MODEL 5107
 FACT SUITABLE FOR INSTALLATION AS A CENTRAL STATION PROTECTED PREMISES INSTALLATION LIMITS UNDER JURISDICTION OF LOCAL AUTHORITY. REFER TO NFPA-71. REPORTING SIGNAL IS DAC

14 TERMINAL STRIP DESCRIPTION

INPUTS

Terminal 1 -	16.5 VAC 60 Hz. (45VA)	
Terminal 2 -	16.5 VAC 60 Hz. (45VA)	
Terminal 3 -	Common negative (circuit ground)	
Terminal 4 -	Zone 3 input (Class B zone)	_____
Terminal 5 -	Zone 4 input (Class B zone)	
Terminal 6 -	Zone 5 input (Class B zone)	
Terminal 7 -	Zone 6 input (Class B zone)	
Terminal 8 -	Zone 7 input (Class B zone)	
Terminal 9 -	Zone 8 input (Class B zone)	**
Terminal 10 -	Zone 1 input (Class A zone)	
Terminal 11 -	Zone 1 input (Class A zone)	
Terminal 12 -	Zone 1 input (Class A zone)	
Terminal 13 -	Zone 1 input (Class A zone)	_____ *3
Terminal 14 -	Zone 2 input (Class A zone)	
Terminal 15 -	Zone 2 input (Class A zone)	
Terminal 16 -	Zone 2 input (Class A zone)	
Terminal 17 -	Zone 2 input (Class A zone)	_____
Terminal 18 -	Loop power, +12 VDC, 50mA max. (Power Limited)	
Terminal 19 -	Loop power, +12 VDC, 50mA max. (Power Limited)	

** SEE SUPERVISED BELL
INSTALLATION BEFORE
CONNECTING ZONE 8

OUTPUTS

Terminal 20 -	Circuit Ground
Terminal 21 -	Bell Positive (Power Limited)
Terminal 22 -	Bell Negative
Terminal 23 -	Not Used
Terminal 24 -	House line #2 Ring
Terminal 25 -	House line #2 Tip
Terminal 26 -	TELCO #2 RING
Terminal 27 -	TELCO #2 TIP
Terminal 28 -	TELCO #1 TIP
Terminal 29 -	TELCO #1 RING
Terminal 30 -	House line #1 Tip
Terminal 31 -	House line #1 Ring
Terminal 32 -	Accessory power, +12 VDC, 1.2A max *1 (fused at 1.5A) (Power Limited)
Terminal 33 -	Smoke detector power, +12 VDC, 0.4A max (fused at 0.5A) *2 (Power Limited)

*1 NOTE: The sum of the current ratings of all 12V accessories connected to terminal 32 and alarm bells must not exceed 1.5A.

*2 NOTE: The maximum number of smoke detectors per panel is 20.

*3 NOTE: The maximum loop impedance is 100 ohms.
(Not including EOL resistor)

15 TRANSIENT VOLTAGE PROTECTION

The Model 5107 Control Panel is protected from transient voltage damage due to lightning or static electricity, in several ways.

1. **AC INPUT PROTECTION** - Fast acting "Transorbs" (Model 7890) connected between each side of the Class II transformer and earth ground (Refer to Figure 3). MOV (Metal Oxide Varistor) protection between each side of the AC input and earth ground.

TELEPHONE CIRCUIT PROTECTION - MOV (Metal Oxide Varistor) protection between TIP/RING and earth ground. Line seizure relays provide an air gap between the 5107's internal circuitry and phone lines.

LOOP INPUT PROTECTION - Fast acting zener diode protection from all Class B loop inputs to ground. Class A loop inputs are isolated from internal circuitry by opto-isolators. MOV protection between all zone inputs and ground.

SYSTEM PROTECTION BY DESIGN - The Model 5107 circuit board layout isolates vulnerable components from known transient sources.

15.1 EARTH GROUND

The key to any good transient protection plan is making the appropriate earth ground connection to all protection devices. Failure to use all of the recommended protection devices will jeopardize the effectiveness of the protection plan.

Finding a good earth ground is always the first step. Connecting to a water pipe may not always provide an earth ground. Check for PVC (plastic) pipe. Electrical ground may not be at a true earth ground potential. Old and/or poor ground connections in the electrical system may allow electrical ground to float at some potential above earth ground. Be observant when selecting your ground source. When in doubt, a grounding rod should be driven into moist earth and used as the earth ground source.

15.2 5107 EARTH GROUND CONNECTIONS

Connect the common lead of the Model 7890 protection device to earth ground (via shielded two-conductor cable and ground pin of the Class II transformer as shown in figure 3).

NOTE: Never connect the system circuit ground to earth ground.

15.3 LIGHTNING PROTECTION

As with any electronic equipment, precautions should be taken when installing the 5107 to protect against high energy transients which can be generated by lightning. The following steps, if observed, will provide the maximum protection against these transients.

- 1) Insure that the AC outlet that you intend to use for the Model 9220 transformer has a "good" connection to earth ground. This can be done at the outlet, using a digital volt meter, by measuring the AC voltage between the "hot" side of the outlet and neutral, then comparing that voltage to the voltage reading made between the "hot" side and the ground connection. The difference between these two readings should not exceed .2 VAC.
- 2) Verify at the breaker or fuse box, that there is a ground wire from the neutral buss bar in the box, to the main cold water pipe at a point closest to where the pipe enters the building. If there is a water meter at this point, be sure that the ground wire is bonded to the pipe on both sides of the meter.

CAUTION: In newer construction the water supply pipe may be plastic. If this is the case, check to see if the breaker box has been bonded to a ground rod. If not, an electrician should be called and a ground rod should be driven into a moist area close to the building and bonded to the breaker box.

- 3) Verify that the neutral buss block in the breaker or fuse box, has a bonding screw connecting it to the box itself.

15.4 MODEL 5107 UL INSTALLATION REQUIREMENT

The Model 5107 has been UL listed as a Control/Communicator for use in a central station fire alarm system under NFPA 71. Copies of NFPA 71 may be obtained by writing to:

National Fire Protection Association
Battery March Park
Quincy, MA 02269

In any installation which is to be submitted for certification you must use UL listed equipment, properly installed by professionals in compliance with the above standards and the National Electrical Code (NFPA 70). The installation must also meet requirements of local authorities. The 5107 must report to a Certified Central Station and the Central Station Company or the Installation Company must provide routine testing and maintenance of the system to insure continued operation in compliance with the requirements.

Index

ac power, 5
accessory wiring, 22
account number, 9
ademco receiver, 10,17
audible trouble signal, 5
automatic self test, 7,17

backup battery, 19
backup power, 5
battery cables, 5
battery charger circuit, 2
battery polarity, 19

central station, 2,7
central station receiver, 2
charging current, 2
class a fire loop, 6
class a zones, 20
class b fire loop, 6
class b zones, 21
clock circuit, 7
coin telephone, 1
control panel, 2
control/communicator, 1,7
control/dialer chip, 17

daily tests, 2
desk top programmer, 5,12
dialer failed light, 2
dialer test switch, 5,7
dual phone line monitor, 2
dual telephone lines, 21

earth ground, 26
eeprom, 5
end of line resistor, 21
expanded hex format, 10

fcc requirements, 1
field repair, 1
fire reset, 5
fire reset switch, 5
fuses, 5

green power light, 5

hand held programmer, 5

initiating devices, 19
installation, 18
integrated circuit, 11

jumper wire, 6

lightning, 19

lightning protection, 27
location, 18

membrane keypad, 7
microprocessor, 2,7
model 5506, 13
model 5510, 14
model 7171 4-wire loop, 23
model 9000 receiver, 8
monitor circuit, 1
mounting, 18

normally open contacts, 21

phone line monitors, 7
plug on connector, 6
power light, 5
power line protection, 19
power transformer, 2,18
printed circuit board, 2
programmer sockets, 12
prom coding form, 11,15
prom insertion, 12
prom programmers, 13
prom removal, 12

radio communications, 1
radionics hex format, 10
receptacle, 19
reporting formats, 7
rj31x, 21

secondary winding, 19
smoke detector, 20
supervised alarm bell, 22
supervised fire loops, 1

telephone lines, 1
telephone wiring, 21
temperature limitations, 18
terminal strip, 25
test, 17
transformer, 1,19
transient protection, 26
transient surge, 19
trouble conditions, 7

ul installation requirement, 27

watch dog circuit, 7
waterflow switch, 15
wheelock alarm bell, 22

zone wiring, 20

IMPORTANT: Silent Knight products should be tested every month (under no circumstances less than every three months) to insure complete and proper operation and proper input and output connections.

LIMITED WARRANTY

Silent Knight Security Systems warrants that the products of its manufacture shall be free from defects in materials or workmanship for one year from the date of invoice if such goods have been properly installed, are subject to normal proper use, and have not been modified in any manner whatsoever. Upon return of the defective product to the nearest Silent Knight dealer, Silent Knight will, at its sole discretion, either repair or replace, at no cost to the customer, such goods as may be of defective material or workmanship. Customers outside the United States are to return products to their distributor for repair.

SILENT KNIGHT SECURITY SYSTEMS SHALL NOT UNDER ANY CIRCUMSTANCES BE LIABLE FOR ANY INCIDENTAL OR CONSEQUENTIAL DAMAGES ARISING FROM LOSS OF PROPERTY OR OTHER DAMAGE OR LOSSES OWING TO THE FAILURE OF SILENT KNIGHT SECURITY SYSTEMS PRODUCTS BEYOND THE COST OF REPAIR OR REPLACEMENT OF ANY DEFECTIVE PRODUCTS.

SILENT KNIGHT SECURITY SYSTEMS MAKES NO WARRANTY OF FITNESS OR MERCHANTABILITY AND NO OTHER WARRANTY, ORAL OR WRITTEN, EXPRESS OR IMPLIED, BEYOND THE ONE YEAR WARRANTY EXPRESSLY SPECIFIED HEREIN.